

Seafari Quest



The Seafari Quest is the choice for small sail or power boats with limited power options. It's fully automatic operation and intuitive control system provides optimal fresh water flush features, ideal safety alarms, and easy maintenance access.

Max Production:
25 Gal (95 Lit) / hour*

Benefits

- Modular design allows you to control system remotely.
- Energy recovery boost - recovers up to 13% on all models.
- Easy access to all maintenance parts.
- Easy, automatic operation.



Photograph courtesy of Fountaine Pajot

*Highest capacity model (Quest 600)



Quest - compact



Quest - modular

Seafari Quest - Specifications | Dimensions

Model	Per Hour	Weight - Compact	SUC 12V	SUC 24V	Motor HP 12/24V
Quest 200	8 Gal / 32 Lit	115 lbs / 52 kg	54	27	0.3
Quest 400	17 Gal / 63 Lit	120 lbs / 54 kg	60	42	0.3
Quest 600	25 Gal / 95 Lit	125 lbs / 57 kg	99	55	0.5

Vane Pump - Electrical

Model	Feed Flow - GPM	Product - GPD	Normal Amp - Draw 12V	Normal Amp - Draw 24V
Quest 200	1.7	200	21	10.5
Quest 400	2.3	400	26	13
Quest 600	3.2	600	38	20

Compact

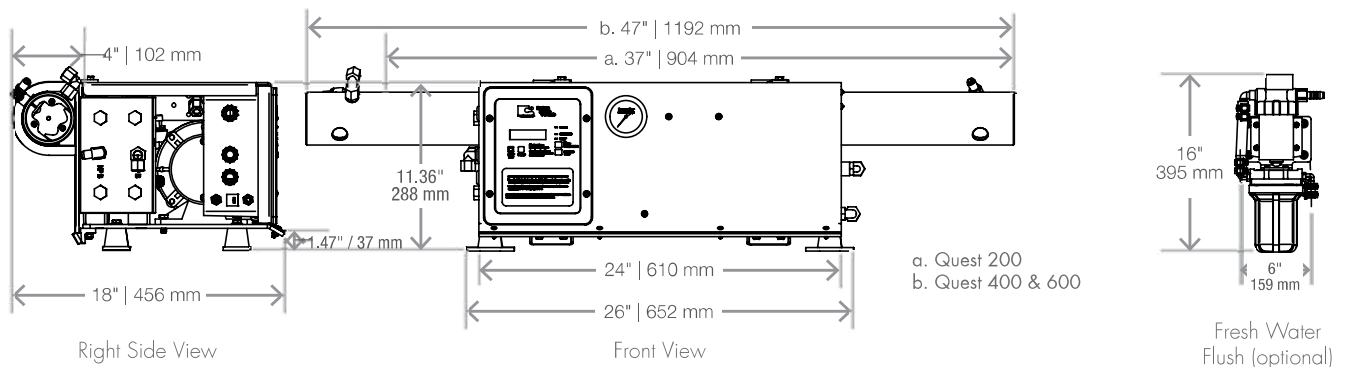

Modular

