



LISTER PETTER

4X90T

Power Range: 33.0 - 53.0 kW

TECHNICAL DATA SHEET



POWER OUTPUT			
		Fixed Speed Continuous(ICXN)	Variable Speed Fuel Stop (IOFN)
3000	kW	-	53
	hp	-	72
2500	kW	-	51
	hp	-	68
2000	kW	-	43
	hp	-	57
1800	kW	32.1	40
	hp	43.0	53
1500	kW	25.6	33
	hp	34.3	44

Rating: ISO 3046-1
Power ratings apply to a fully run-in engine without radiator, fan or other power absorbing accessories.

Approximate Derating: ISO 3046-1
Altitude - 4.0% for every 300m (1000ft) higher than 100m (330ft) above sea level.
Temperature - 2.0% for every 5°C (10°F) above 25°C (77°F).

TORQUE	
Variable Speed Fuel Stop (IOFN)	
Nm	170
lbf ft	125
Nm	193
lbf ft	142
Nm	200
lbf ft	147
Nm	200
lbf ft	147
Nm	188
lbf ft	138

APPROXIMATE DIMENSIONS		
	mm	inch
A	711	28.0
B	489	19.3
C	673	26.5

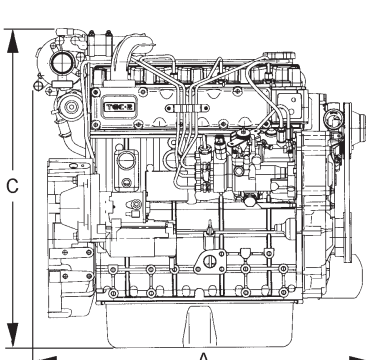
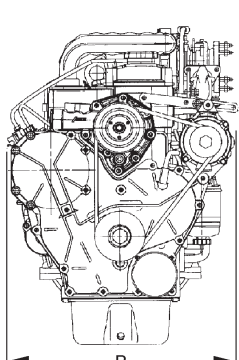
The figures given are for guidance, and should not be used for installation purposes.
The 'A' dimension is taken from the outside faces of the radiator fan and flywheel housing.

MECHANICAL DATA

Bore	mm	90
	in	3.54
Stroke	mm	90
	in	3.54
Cylinder Capacity	litre	2.29
	in ³	140
Dry Weight (approx)	kg	220
	lb	485
Note: Dry weight is inclusive of the starter and alternator.		

EMISSIONS CERTIFICATION

These engines meet the requirements of EPA Tier 2 Regulations and EU NRMM Directive Stage 2. For details of emissions certification please refer to Lister-Petter or your local Lister-Petter Distributor.

CONSTRUCTION

- Ribbed, thin-wall cast iron crankcase for quiet operation.
- Crankcase with a detachable sump.
- Closed circuit breather system.

COMBUSTION SYSTEMS

- Rotary fuel injection pump.
- High pressure re-entrant bowl direct injection system.

STARTING

- 12 volt electric.

ROTATION

- Counter-clockwise, looking at the flywheel end.

COOLING

- Water circulation pump driven by a long-life belt.
- Engine includes a thermostat and an integrated bypass system.
- Designed for ambients up to 52°C (125°F).

LUBRICATION

- Designed to run at high angles of inclination and includes a full flow spin-on cartridge filter.
- Service free hydraulic tappets.
- Positive displacement, gear driven lubricating oil pump
- Oil service interval of 500 hours.

GOVERNING

- Fixed and variable speed models.

DRIVES

- Full power is available at the flywheel end for axial or radial drives.
- Option for mounting two laid back hydraulic power take-offs from the gear end cover.

MOUNTING

- Automotive style mounting pads on the crankcase.

STANDARD EQUIPMENT

- Flywheel with SAE J620 7.5" disc face.
- Flywheel housing with SAE5 flange.
- Fuel filter with water trap.
- Fuel lift pump.
- Fixed and variable speed models.
- 12 volt starter motor.
- 50 amp alternator.
- Lubricating oil filter.
- Water circulation pump and thermostat.
- Lifting eyes.
- Operators Handbook.

ADDITIONAL INFORMATION

Comprehensive mechanical data is available from Lister-Petter Customer Engineering.

Technical data regarding these engines will be published as soon as possible.

This information is intended for the assistance of users and is based upon results obtained from tests performed at the place of manufacture. This company does not guarantee that the same results will be obtained elsewhere under different conditions and in certain applications. The information in this brochure does not form a part of any contract, guarantee or warranty. We have made efforts to ensure that the information is accurate, but reserve the right to amend specifications and information without notice and without obligation or liability.

Distributor Address

Lister Petter UK Limited
Dursley, Gloucestershire
GL11 4HS England

Tel: +44 (0)1453 544141
E-mail: sales@lister-petter.co.uk
Fax: +44 (0)1453 546732
<http://www.lister-petter.co.uk>