

# AS3000 Automatic Engine Controller

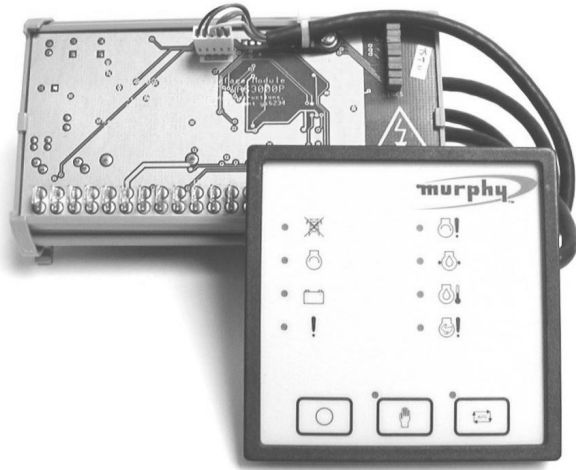

- **Auto crank disconnect**
- **Multi-attempt starting**
- **Fault warning and shutdown**
- **Reduced panel wiring**
- **Simple set-up**

## Description

The AS3000 provides automatic start up, fault monitoring and shutdown control for engine driven applications. The unique two-module design, with a single interconnecting lead, gives reduced panel wiring and installation. This simple, compact unit is ideally suited to small engine and generator panels.

Key features:-

- Multi-attempt cranking with auto crank disconnect
- Automatic or manual modes, selected by front facia pushbuttons. Control inputs for optional security keyswitch.
- **User interface module:** front of panel mounted, 92mm square DIN cut-out. Environmental sealing to IP65
- **Panel interface module:** DIN rail mounted PCB tray.
- Fault shutdown and indication system. Low oil pressure, high coolant temperature and auxiliary inputs are fitted to both modules, allowing use with engine mounted fault switches or facia mounted Swichgage® units.
- Speed sensing (auto crank disconnect and overspeed shutdown) is via magnetic pickup, generator AC or remote contact. Speed calibration is automatic and adjustment free.
- Mains charger/charge alternator fail warning LED.
- Easy setup of operating options using circuit board links.
- Generator AC Hz meter output, 0 – 5V.

## Warranty

A two year limited warranty on materials and workmanship is given with this Murphy product. Details are available on request and are packed with each unit.

## Product Specification

<b>Power supply:</b>	
Continuous voltage range	8 – 35 VDC
Brown out voltage	< 5 VDC for 2 secs (recovery to 8V)
Blackout voltage	0V for 50mS (from 10V, recovery to 5V)
Overvoltage withstand	50 VDC for 5 seconds (to SAEJ1810 load dump immunity)
Reverse voltage withstand	100 VDC continuous
Current consumption (standby)	50mA
Current consumption (max)	500mA (plus output loads)
<b>DC Inputs:</b>	
Oil pressure, coolant temp, auxiliary and charger faults	closed to negative DC ( $\pm 3V$ ) on fault
Remote start positive	open from positive DC to start
Remote start negative	close to negative DC ( $\pm 3V$ ) to start
Lamp test	close to negative DC ( $\pm 3V$ ) to activate
DC input protection	$\pm 50$ VDC max.
<b>AC Inputs:</b>	
Magnetic pickup	3 – 60 VAC, 50Hz – 10 kHz.
Generator AC	600 VAC max (L-L or L-N), 50/60 Hz.
<b>Outputs:</b>	
Fuel	positive DC (semiconductor), 5A max.
Crank, preheat	positive DC (semiconductor), 2A max.
Common alarm, fault lockout	negative DC (semiconductor), 300mA max.
Generator Hz. meter	0 – 5VDC (@ 45–65Hz), 10mA max
<b>Physical:</b>	
Dimensions	see overleaf
Operating temperature	-10 to +65°C
Relative humidity	95% @ 60 °C
Environmental protection	AS3000U front: IP65, NEMA4
Vibration	ISO 88528 pt.9, & 3 axis 3g
Weight	AS3000U: approx. 250g AS300P: approx. 160g

## System Overview

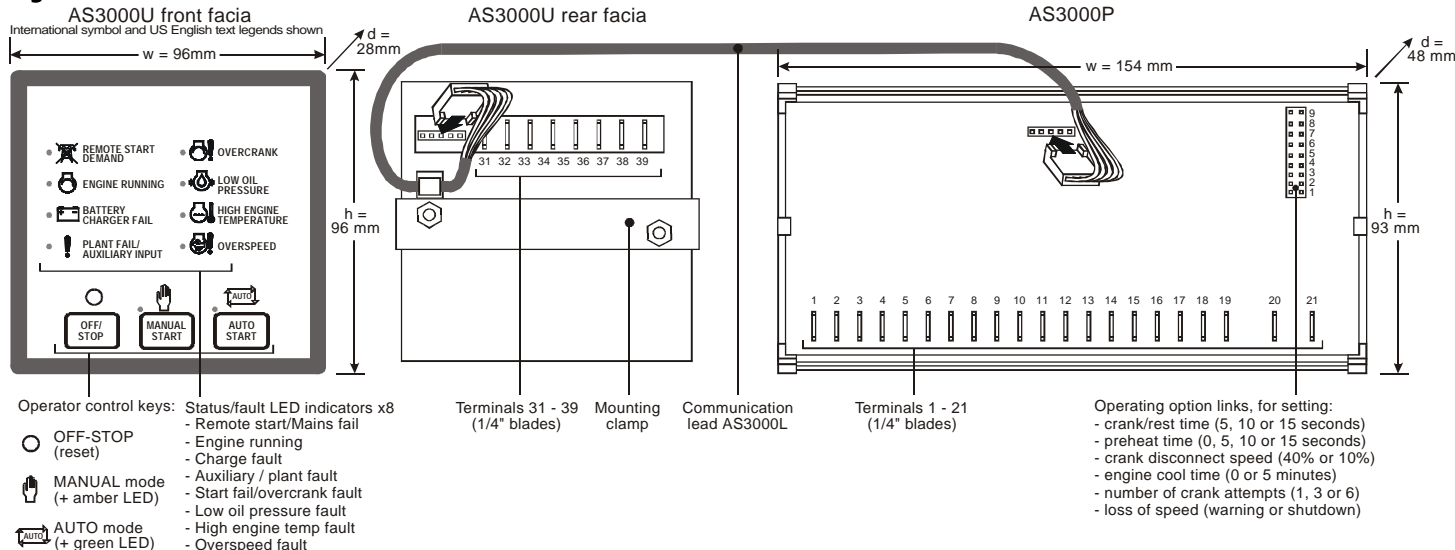

## Electrical Connection

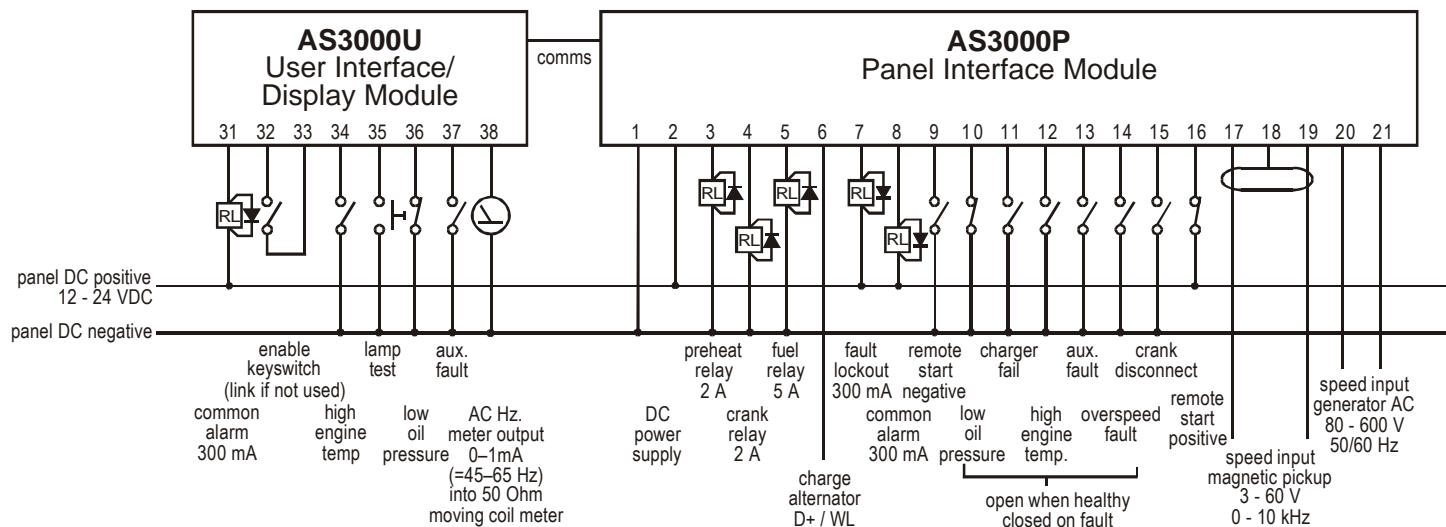

## How to order

Stock no. Unit type

### Complete systems:-

- 41.70.0092 AS3000 system, front facia symbols
- 41.70.0093 AS3000 system, front facia US English

### Components:-

- 41.70.0095 AS3000U user interface, international symbols
- 41.70.0096 AS3000U user interface, US English text
- 41.70.0097 AS3000P panel interface module
- 41.70.0098 AS3000L communication lead



**FWMurphy**

PO Box 470248  
Tulsa, Oklahoma 74147, USA  
tel: (918) 627 3550  
fax: (918) 664 6146  
email: sales@fwmurphy.com  
web: www.fwmurphy.com

CONTROL SYSTEMS AND SERVICES DIVISION  
PO Box 1819, Rosenberg, Texas 77471, USA  
tel: (281) 342 0297  
fax: (281) 341 6006  
email: sales@fwmurphy.com

MURPHY DE MEXICO S.A. DE C.V.  
Blvd. Antonio Rocha Cordero 300, Fracción del Aguaje  
San Luis Potosí, S.L.P. México 78384  
tel: + 52 444 8206264  
fax: + 52 444 8206336  
email: ventasmex@murphymex.com.mx  
web: www.murphymex.com.mx

FRANK W. MURPHY LTD.  
Church Rd, Laverstock, Salisbury, SP1 1QZ, UK  
tel: +44 1722 410055  
fax: +44 1722 410088  
email: sales@fwmurphy.co.uk  
web: www.fwmurphy.co.uk

MURPHY SWITCH OF CALIFORNIA  
41343 12th Street West,  
Palmdale, CA 93551-1442, USA  
tel: (661) 272 4700  
fax: (661) 947 7570  
email: sales@murphyswitch.com  
web: www.murphyswitch.com

MACQUARRIE CORPORATION  
1620 Hume Highway,  
Campbellfield, Victoria 3061, Australia  
tel: +61 3 9358 5555  
fax: +61 3 9358 5558  
email: murphy@macquarrie.com.au



In order to consistently bring you the highest quality, full featured products, we reserve the right to change our specifications and designs at any time.