

Autostart AS731 Automatic Generator Controller



- **Automatic or manual generator control**
- **Fully configurable timers, inputs and outputs**
- **Remote monitoring and control software, PC/Windows® compatible**

Description

The AS731 provides fully automatic control, fault monitoring and shutdown of a standby diesel generator.

Features include:-

- Automatic or manual control
- 32 character, back-lit LCD displays engine and generator parameters
- Full configurability of inputs, outputs, timers, trip levels and control options (details overleaf).
- Monitoring, display and programmable fault limits for 3 phase generator voltage, frequency and current.
- Monitoring, display and programmable warning/shutdown levels for engine oil pressure and temperature.
- Timed generator contactor control
- Remote communications, with software for PC/Windows®

Application

The AS731 is a 'full function' controller, designed for use in unmanned, standby diesel generator applications. The comprehensive control, measurement and display features allow this unit to be used in place of multiple control units, trip units and indicating gauges, and at a fraction of the cost.

The RS232 communication port and free of charge Windows® compatible software provide remote monitoring, control and automatic fault notification, wherever the generator location.

For further details, visit www.fwmurphy.co.uk/as731

Warranty

A two year limited warranty on materials and workmanship is given with this Murphy product. Details are available on request and are packed with each unit.

Product specification

Power supply:	
Operating voltage: steady state range	5 – 40 V DC continuous
crank brown-out	to 0 V for >=100mS
Current consumption: standby (typ)	95mA @ 12V, 55mA @ 24V
cranking (typ)	280mA @ 12V, 170mA @ 24V
Inputs:	
DC inputs:-	
Inputs 1 (oil pressure) and 2 (engine temperature)	switch (open or closed) or analogue (Murphy, Datcon, VDO 5 or 7 bar), wired to negative DC open or closed to negative DC
Inputs 3 – 5	
Generator AC (1, 2 or 3 phase):-	
voltage range	90–300 VAC rms L–N
voltage display resolution	1 VAC
frequency measurement range	0 – 99 Hz.
frequency display accuracy	<= 2% of full scale
frequency display resolution	1 Hz.
Magnetic pickup:	
voltage range	2.5 – 25 V AC rms
frequency measurement range	0 – 10 kHz.
engine RPM display accuracy	<= 2% of full scale
engine RPM display resolution	10 RPM
AC current sensing inputs:	
operating range	designed for use with 5 Amp CT's primary ratings 10 to 5000 Amps
Outputs:	
Start and fuel relays	positive DC (switched relay) combined rating 16 A max @ 24VDC
Programmable output 1 (default setting: Gen. Contactor)	volt free SPNO relay 5 A max. @ 240 V AC
Programmable outputs 2 – 4	negative DC (semiconductor) 500 mA max. @ 33 V DC
Physical:	
Overall dimensions (W x H x D)	144 x 96 x 162 mm
Panel cut-out size (W x H)	DIN standard 140 x 92 mm
Weight	approx. 770 g
Operating ambient temperature	-10 to +55 °C

Front facia

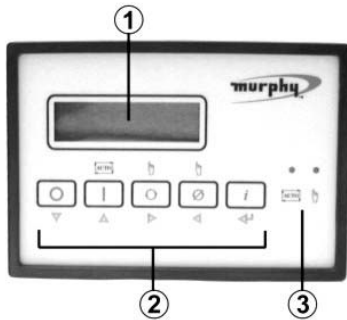

- 1) 2 line x 16 character backlit liquid crystal display
- 2) Operator control keys:-
 - Off/stop/reset
 - On/Auto mode
 - Manual mode start
 - Manual mode stop
 - Info (scroll display)
- 3) Auto/manual mode LED indication

Rear facia

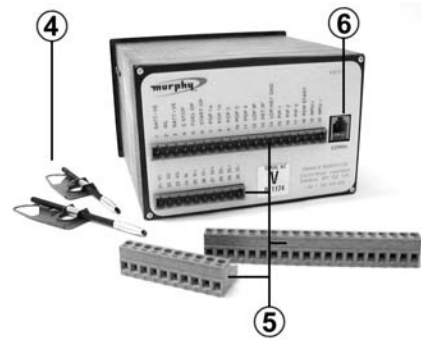

- 4) Mounting clamps
- 5) 2 x two part, screw terminal blocks, 1 – 20 and 21 – 30
- 6) RS232 communication port (RJ11 connector)

Electrical connection

- | | | | |
|----|--|----|-------------------------------|
| 1 | Battery / DC negative supply | 21 | Generator AC V1 |
| 2 | Charge fail / WL | 22 | Generator AC V2 |
| 3 | Battery / DC positive supply | 23 | Generator AC V3 |
| 4 | Emergency stop (positive input for fuel/starter outputs) | 24 | Generator AC N |
| 5 | Fuel output (positive DC) | 25 | Generator current (5A CT) I1+ |
| 6 | Start output (positive DC) | 26 | Generator current (5A CT) I1- |
| 7 | Output 1a (volt free relay contacts) | 27 | Generator current (5A CT) I2+ |
| 8 | Output 1b (volt free relay contacts) | 28 | Generator current (5A CT) I2- |
| 9 | Output 2 (negative DC, semiconductor) | 29 | Generator current (5A CT) I3+ |
| 10 | Output 3 (negative DC, semiconductor) | 30 | Generator current (5A CT) I3- |
| 11 | Output 4 (negative DC, semiconductor) | | |
| 12 | Input 1: oil pressure (sender or switch, to negative DC) | | |
| 13 | Input 2: engine temp. (sender or switch, to negative DC) | | |
| 14 | Input 1/2 return/ground | | |
| 15 | Input 3 (switch, close to / open from negative DC) | | |
| 16 | Input 4 (switch, close to / open from negative DC) | | |
| 17 | Input 5 (switch, close to / open from negative DC) | | |
| 18 | Remote start input (open from / close to positive DC) | | |
| 19 | Magnetic pickup + / high | | |
| 20 | Magnetic pickup - / low | | |

Typical connection (automatic mains fail application)

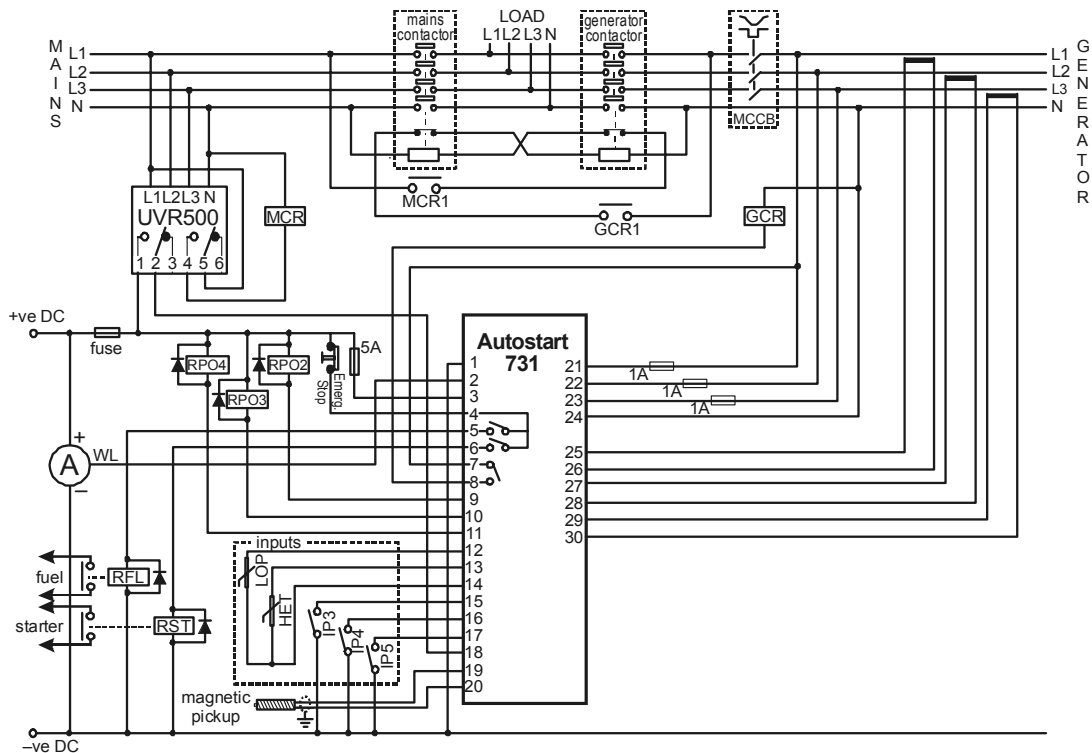

AS7CN PC software

Software model AS7CN is available free of charge from www.fwmurphy.co.uk/download. With a local or modem RS232 link in place between an AS731 and PC, the Windows®-based software allows the PC user to program, monitor and control the AS731. The AS731 may also be configured to dial-out to a remote PC in the event of fault conditions; the PC software may be set to receive such calls and log information about the location, date/time and type of fault.

Typical program mode screen:-

(see 'program options' below for full listing)

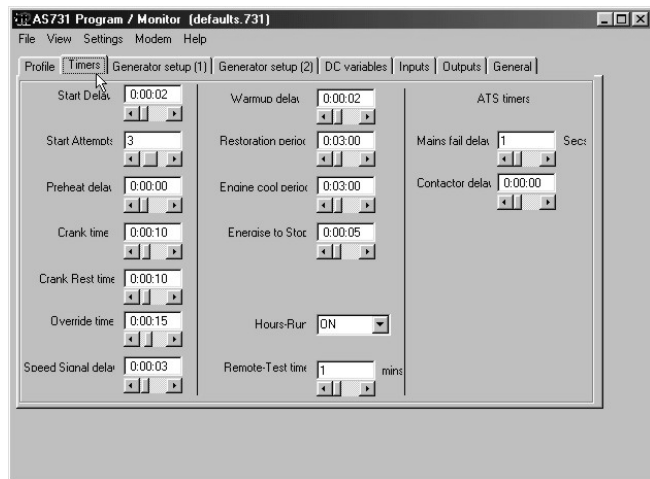

Typical fault notification screen:-

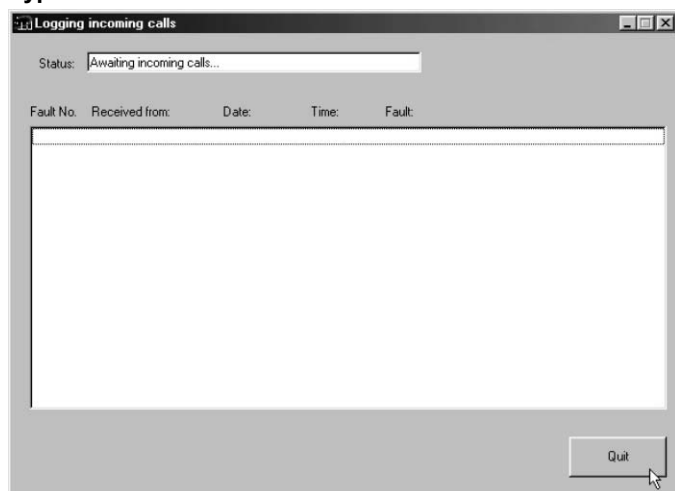

Typical monitoring screen (single genset detail):-

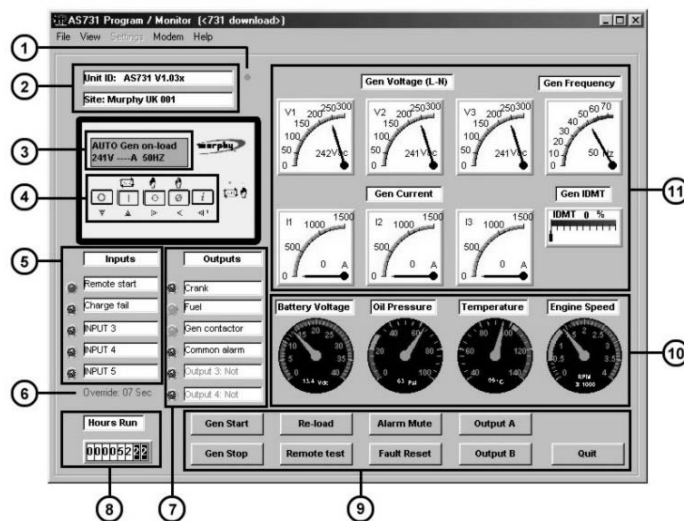

1. Communication status (flashes during RS232 activity)
2. Type, build level and name of connected unit
3. System status (mimics local AS731 display)
4. Remote operator controls
5. Input functions and status
6. Override timer status
7. Output functions and status
8. Hours run counter
9. Remote operator controls
10. Gauges for DC volts, engine RPM, oil pressure and coolant temperature
11. Gauges for generator AC volts, amps, Hz, also overcurrent IDMT trip response

Program options

The AS731 has over 70 firmware configurable functions, allowing complete flexibility of inputs, outputs, timers and engine/generator control options - full details are available in document mi6128. Configuration is carried out using the front facia keys and LCD, or by software AS7CN and RS232 link.

Timers:	Start delay; crank time; crank rest time; number of start attempts; alarm override (on start); speed signal/overshoot delay; engine warm-up delay; (mains) restore delay; engine cool time; energised to stop time; remote test run time.
Battery DC	Low and high battery volts warning; charge alternator fail voltage; charge start (auto start on low battery) voltage; charge start run period.
Generator AC	1/2/3 phase selection; over/under voltage levels; under voltage response; over/under speed/frequency levels; under speed/freq. response. Over current settings: full load current; CT ratio; IDMT response constant; warning/shutdown response.
Inputs	2 x analog/switch inputs, 1 (oil pressure) and 2 (engine temp): sender/switch type; display units; warning and shutdown levels. 3 x switch inputs: open/closed to activate; input 'action' (15 options including shutdown fault, warning fault, load release, test, start, stop, manual restore, etc); custom fault messages.
Outputs	4 outputs, each with 50+ control or fault signalling options.
General	Access ID codes; unit/site ID; custom power up message.

AS731 RS232 communication

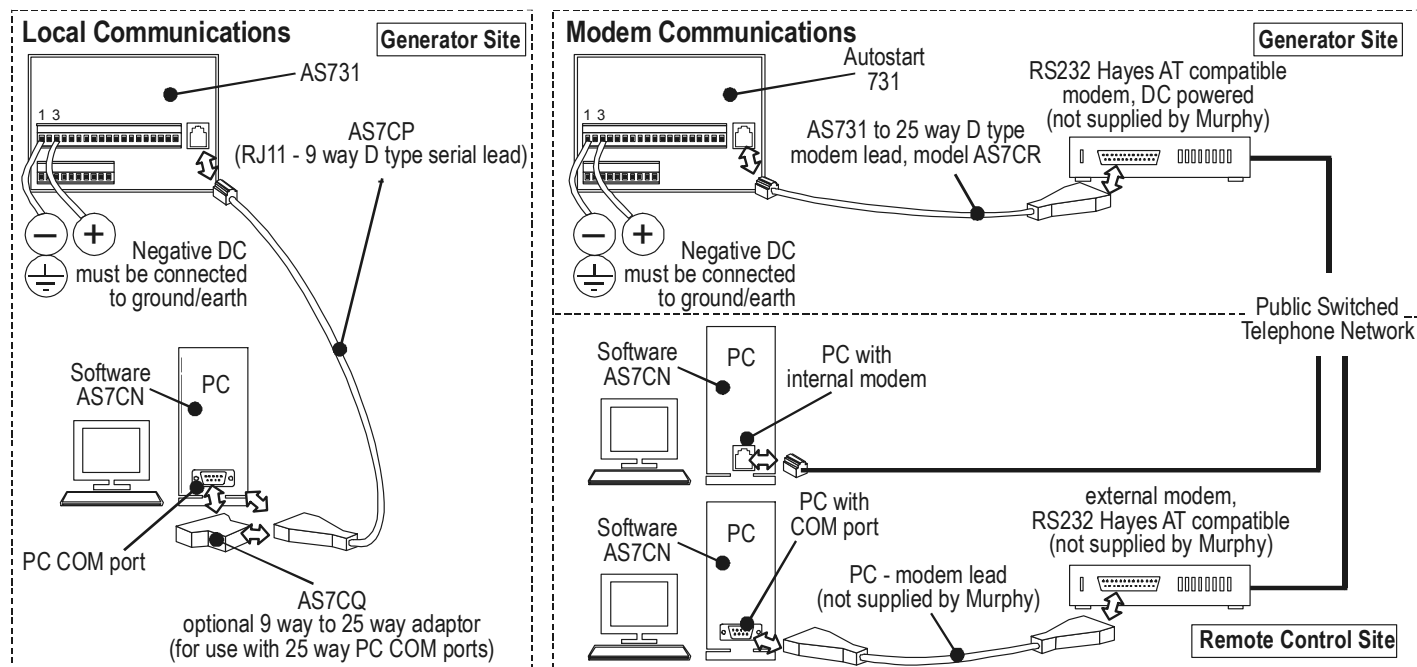

How to order

Stock no.	Model/description
76.70.0271	AS731 generator controller

Optional communication accessories:-

76.70.0310	AS7CP local communication (null modem) lead, for use with 9 way PC COM ports
76.70.0312	AS7CQ adaptor for above, for use with 25 way PC COM ports
76.70.0311	AS7CR modem (remote) communication lead (RJ11 to 25 way D type)

Software model AS7CN is available for free of charge download from our web site:
www.fwmurphy.co.uk/download

Warranty

A two year limited warranty on materials and workmanship is given with this Murphy product. Details are available on request and are packed with each unit.

Further information

Doc. ref.	Title
ms6343	NEW! AS732 bulletin. <i>All the features of the AS731 plus RS485 MODBUS network for remote interfacing and multi-genset communication.</i>
Mi6128	AS731/732 installation A: fitting and connection
mi6129	AS731/732 installation B: programming
mi6243	AS731/732 installation C: AS730 to AS731/AS732 retrofitting
mi6130	AS731/732 operation
mi6131	AS731/732 and PC software model AS7CN



FWMurphy

PO Box 470248
 Tulsa, Oklahoma 74147, USA
 tel: (918) 317 4100
 fax: (918) 317 4266
 email: sales@fwmurphy.com
 web: www.fwmurphy.com

CONTROL SYSTEMS AND SERVICES DIVISION
 PO Box 1819, Rosenberg, Texas 77471, USA
 tel: (281) 342 0297
 fax: (281) 341 6006
 email: sales@fwmurphy.com

MURPHY DE MEXICO S.A. DE C.V.
 Blvd. Antonio Rocha Cordero 300, Fracción del Aguaje
 San Luis Potosí, S.L.P. México 78384
 tel: + 52 444 8206264
 fax: + 52 444 8206336
 email: ventasmex@murphymex.com.mx
 web: www.murphymex.com.mx

FRANK W. MURPHY LTD.
 Church Rd., Laverstock, Salisbury, SP1 1QZ, UK
 tel: +44 1722 410055
 fax: +44 1722 410088
 email: sales@fwmurphy.co.uk
 web: www.fwmurphy.co.uk

MURPHY SWITCH OF CALIFORNIA
 41343 12th Street West,
 Palmdale, CA 93551-1442, USA
 tel: (661) 272 4700
 fax: (661) 947 7570
 email: sales@murphyswitch.com
 web: www.murphyswitch.com

MACQUARRIE CORPORATION
 1620 Hume Highway,
 Campbellfield, Victoria 3061, Australia
 tel: +61 3 9358 5555
 fax: +61 3 9358 5558
 email: murphy@macquarrie.com.au



In order to consistently bring you the highest quality, full featured products, we reserve the right to change our specifications and designs at any time.